

Red Deer Ironworks

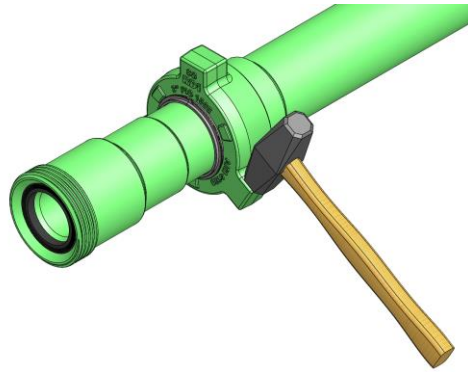

Hammer Union Connection Operation Manual

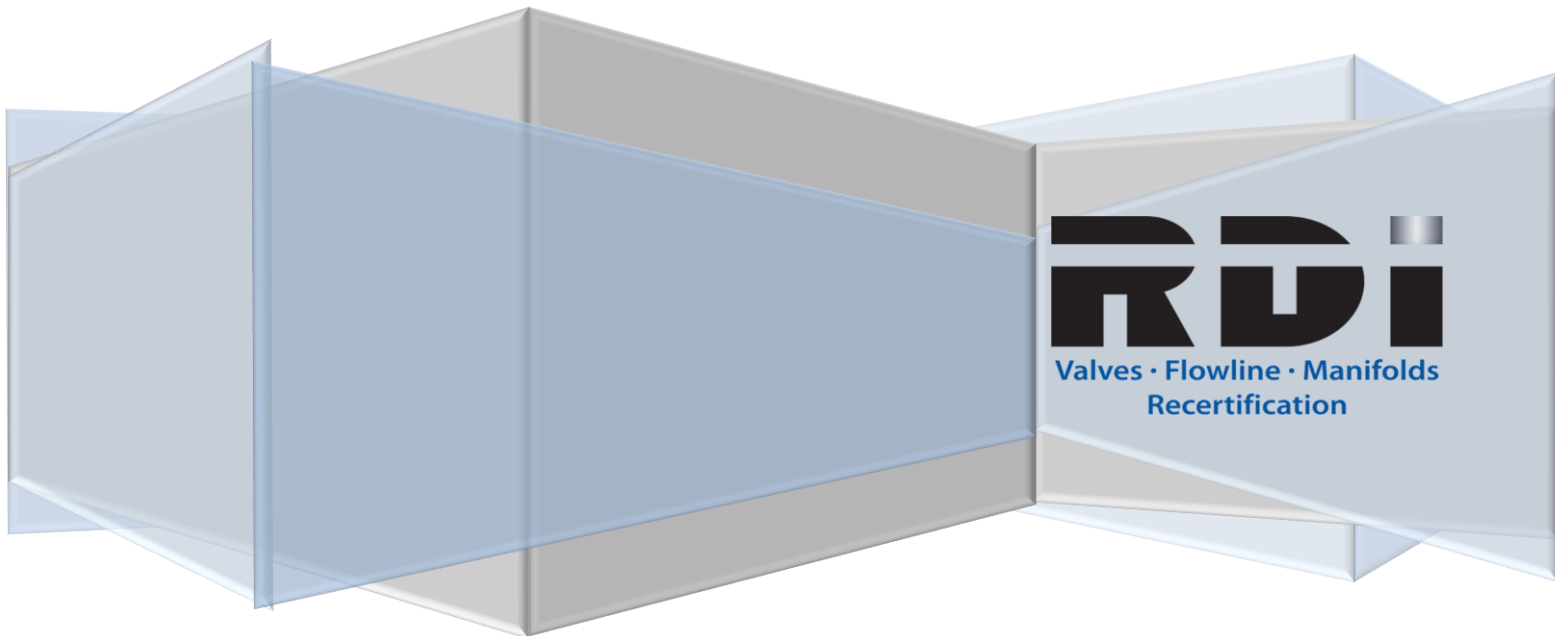

Hammer unions have been used since the 1930's. In the 1950's FMC acquired Weco, the original company that manufactured these connections. All the current hammer unions are based on the original Weco design. In 2009 discussion on development of a technical specification (API 7HU2) for hammer unions started and in 2013 RDI joined the committee for API 7HU2.

There are 6 components that make up a detachable hammer union connection. The female thread (1), union seal (2), three-piece segment set (3), wingnut (4), snap ring (5) and the male end (6).

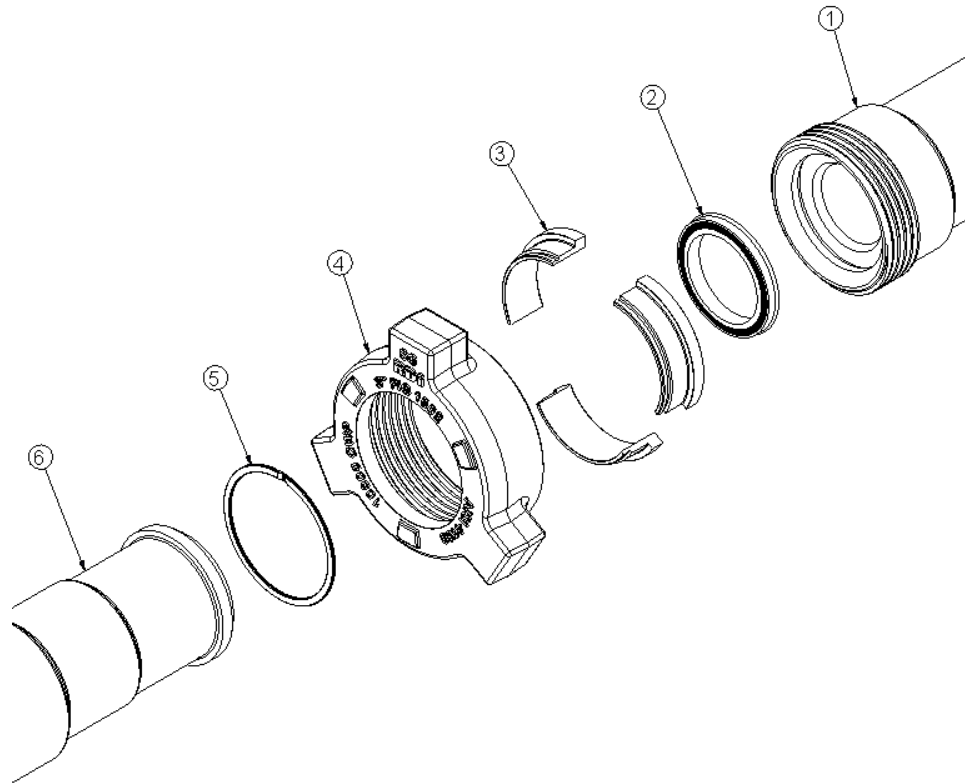

Typical Hammer Union Connection Components

To assemble a hammer union connection the union seal (2) must be inserted into the female thread (1). The snap ring (5) is then installed onto the male end (6). The wingnut (4) is then slid over the male end and pushed back far enough to allow installation of the segment set (3) onto the male end. The segments are what keep the wingnut from sliding off the male end. The wingnut is then pulled forward over the segments and the snap ring is installed into the groove on the back of the segments. The snap ring keeps the wingnut from sliding back over the segments and the segments from falling out.

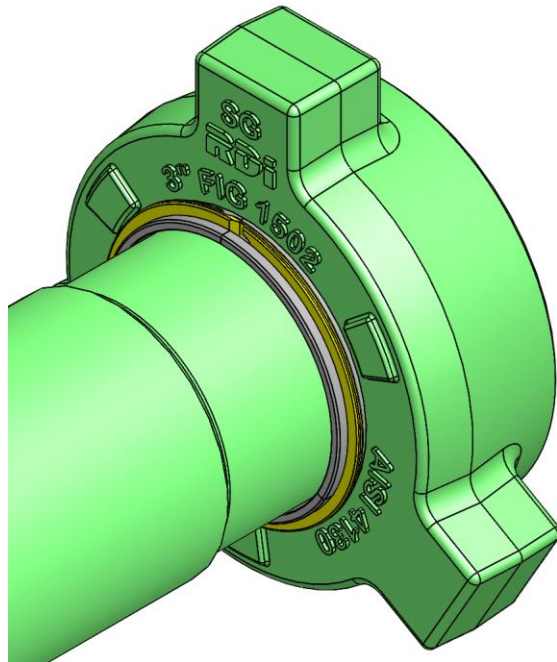

Wingnut, segments and snap ring installed on male end

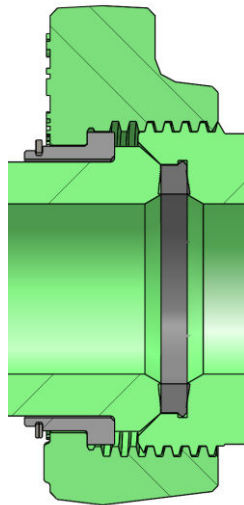

Hammer union connection made up

To make up a hammer union connection the tip of the male end is inserted into the female end against the union seal. The wingnut is then threaded onto the female thread until hand tight.

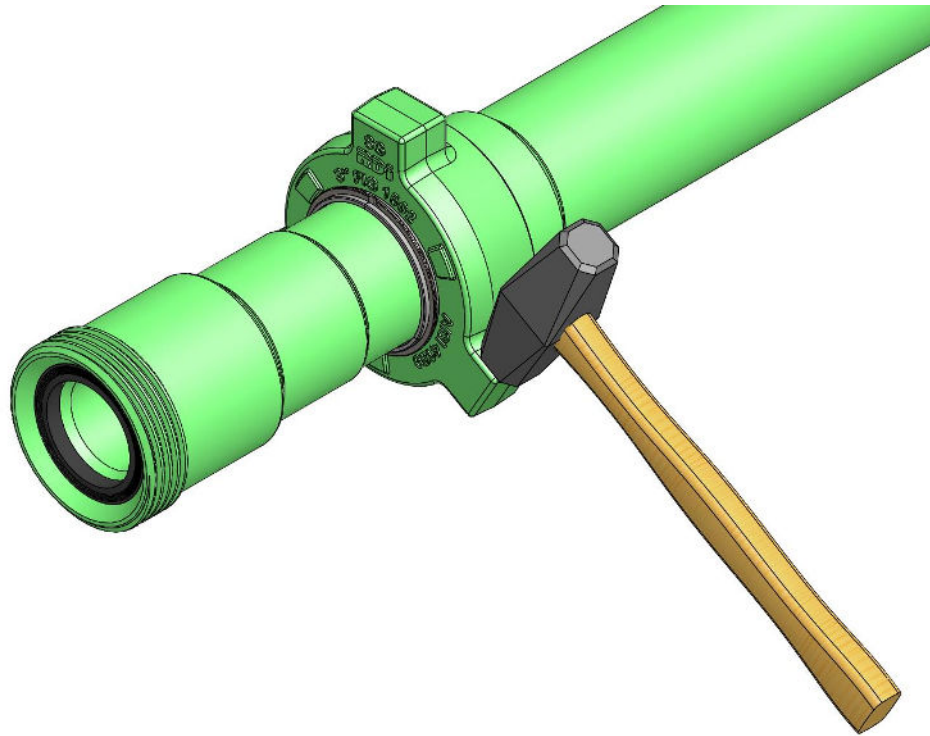

A hammer is then used to hit the lugs on the wingnut to tighten it up until the cone of the male end contacts the taper in the female end (metal to metal contact). At this point the union seal is compressed between the male and female ends creating the seal.

Non-Detachable wingnuts are similar except that the wingnut is not removable, i.e. was installed before the male end was welded onto the rest of the part. As such they do not have segments or a snap ring to hold the segments, however, they connection is hammered tight in the same manner.

CAUTION: Always wear appropriate PPE (safety glasses, gloves, steel toed boots, etc.) to prevent injury.

CAUTION: Always confirm the size and Figure of the connections. Mixing different size and figure components may result in catastrophic failure which may lead injury or death.

Contact your local repair shop for guidance on when to replace worn wingnuts.

RDI Sales & Service Centers

For a list of our locations visit our website @
<https://rdironworks.com/contact-a-location-near-you/>.



Toll Free Phone: 855.973.4733

Toll Free Fax: 855.573.4473

Email: info@rdironworks.com



Valves • Flowline • Manifolds
Recertification

RDIRONWORKS.COM